

Ergofocus Holographik® Decorative range

Availability : NOW

Production time : in BLACK = 16 weeks minimum, starting from receipt of your signed drawing agreement
in WHITE = 19 weeks minimum, starting from receipt of your signed drawing agreement



Ergofocus Holographik®
The irreverence of a dream

Folly and wisdom share the same space, Ergofocus Holographik® shows what virtual flames can really do. This is where an iconic object, designed by Dominique Imbert 50 years ago, meets the best of what modern optical technology can offer.

The concept is based on the projection of a moving image of flames onto optical quality glass amidst decorative ceramic logs, embers and artificial lighting effects.

The optical illusion is completed by the sonic illusion of spluttering and crackling flames.

The Ergofocus Holographik® is the first ever adjustable hanging fireplace with an in-built holographic display inside the flue. Our holographic system's new technology, notably the optical glass screen, has been patented and is now recognised as the most realistic system of its kind currently available on the market. This digital experience is an invitation to rest your eyes and spirit and enter into a state of serenity and inner peace.

The holographic fire is totally realistic fulfilling all the promises of the real thing, it finally brings the wood-fireplace into the realm of interior decoration without all of the restrictions associated with heat and pollution.

With the Holographik® fire, Focus transports what we know of fire and flames into the virtual realm and takes us into a sensory future beyond the material world. The Holographik® fire is a genuine fireplace revolution.

Fire has changed, forever.

Overall dimensions

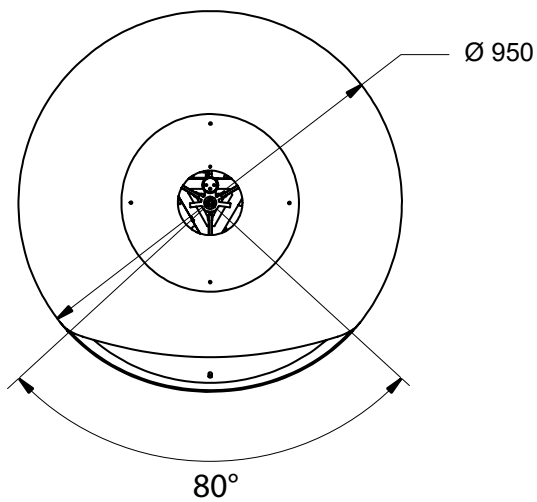
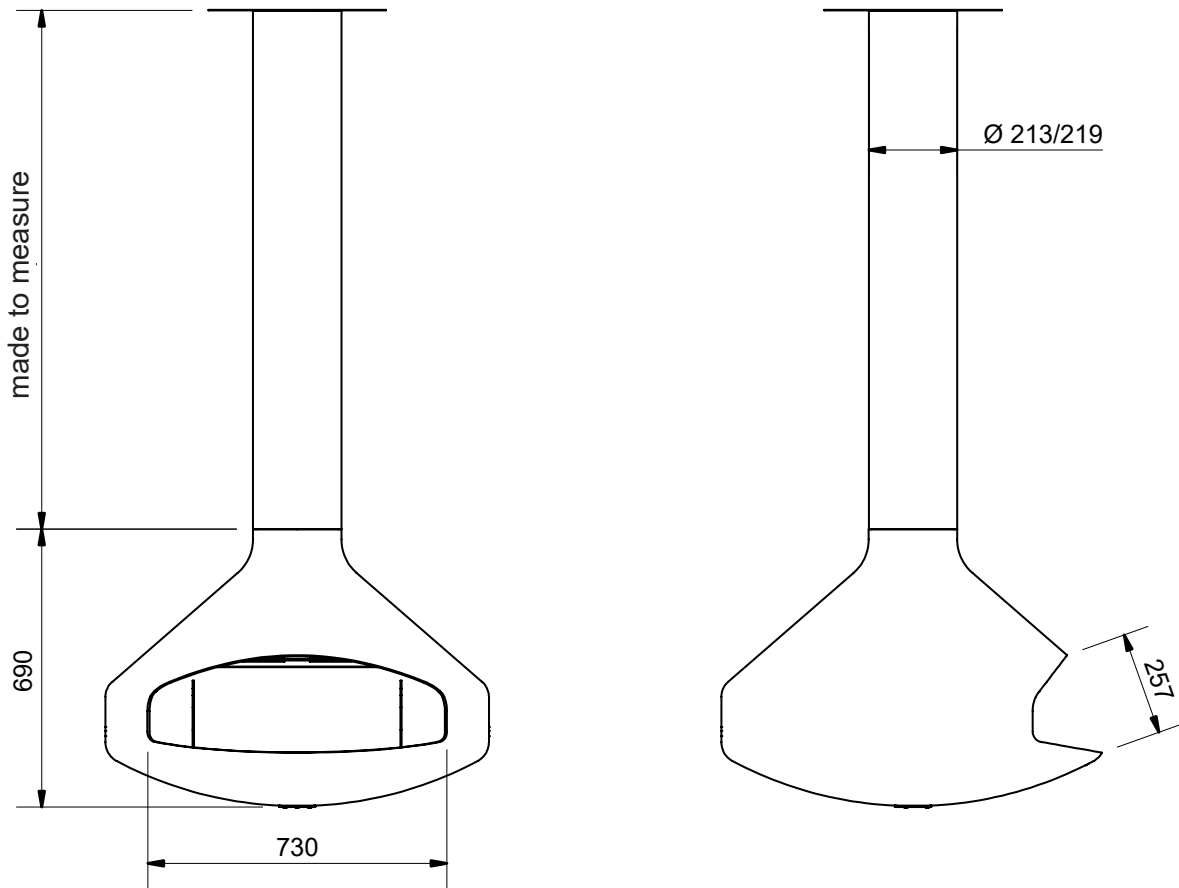

This document is the property of Atelier Dominique Imbert SAS. It is intended exclusively for the use of our authorised dealers. It contains privileged and confidential information. Divulging this document or its contents to any third party without prior written permission is strictly forbidden and will result in legal action for fraud.

Fireplace elements



This document is the property of Atelier Dominique Imbert SAS. It is intended exclusively for the use of our authorised dealers. It contains privileged and confidential information. Divulging this document or its contents to any third party without prior written permission is strictly forbidden and will result in legal action for fraud.

Operation

Technical Specifications:

- mains power supply = 220-240 V 50 Hz
- power rating = 26 W

Electrical power supply: the power supply must be fitted with a 30 mA residual current circuit breaker (RCCB).

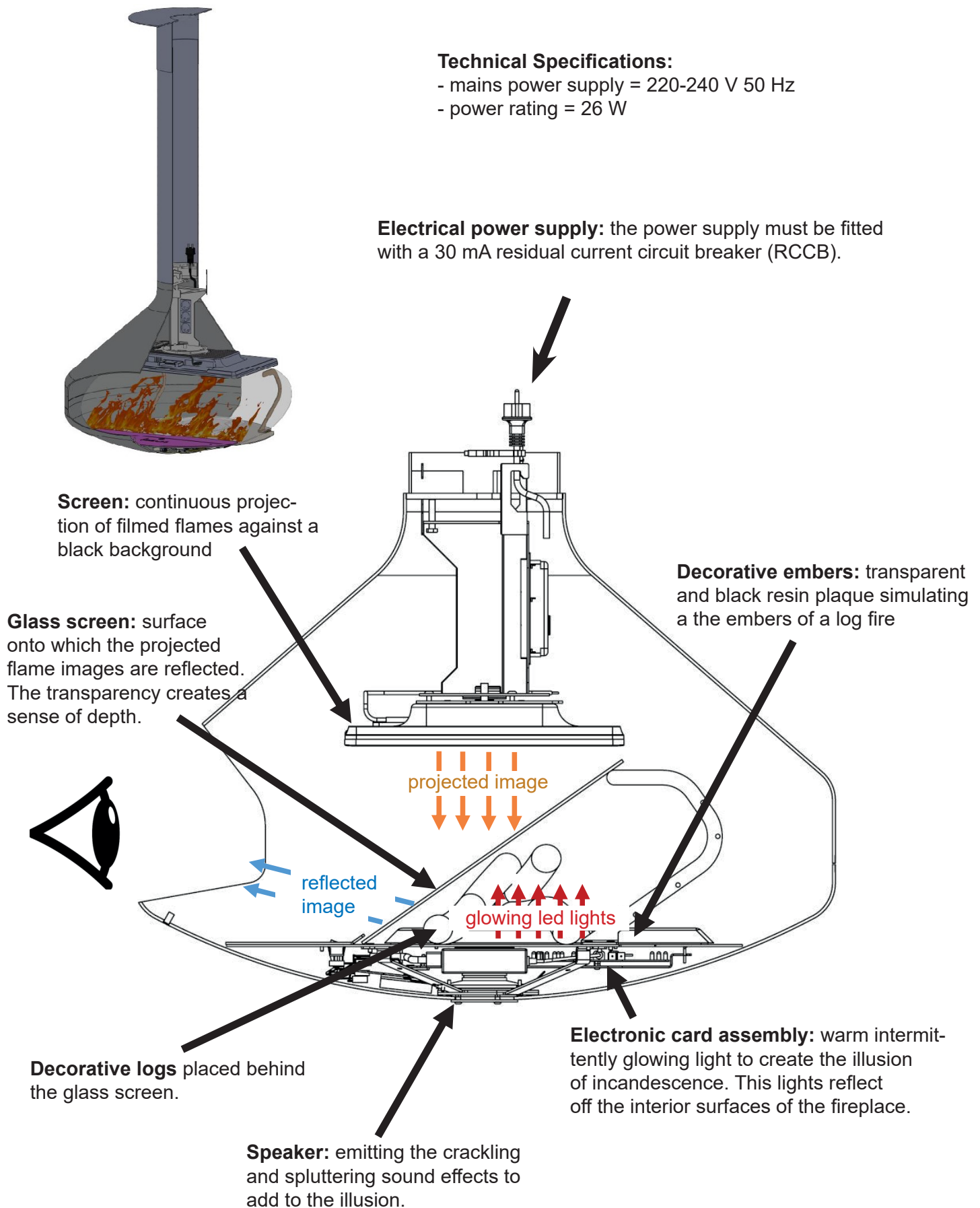

This document is the property of Atelier Dominique Imbert SAS. It is intended exclusively for the use of our authorised dealers. It contains privileged and confidential information. Divulging this document or its contents to any third party without prior written permission is strictly forbidden and will result in legal action for fraud.

Packaging



Exterior box dimensions (mm): 1050 x 1050 x 1150 height

Box weight (including fireplace): 105 kg

Weight of fireplace alone (excl. packaging): 85 kg

Weight of chimney flue alone (excl. packaging): 16kg per linear metre